

REV.	ECN NO.	DESCRIPTION	DESIGN	DATE
A		INITIAL	Kai	2018.03.29

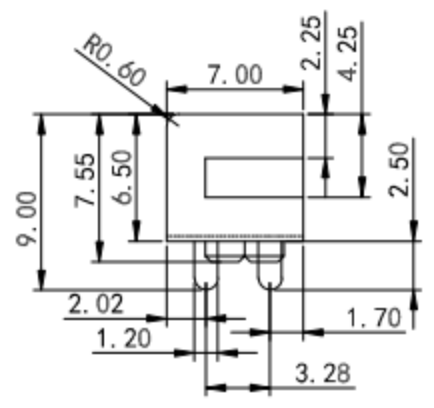

No. of Pins	Dimension			
	DIM.A	DIM.B	DIM.C	DIM.D
4	19.85	17.00	6.00	11.00
5	21.85	19.00	8.00	13.00
6	23.85	21.00	10.00	15.00
7	25.85	23.00	12.00	17.00
8	27.85	25.00	14.00	19.00
9	29.85	27.00	16.00	21.00
10	31.85	29.00	18.00	23.00
11	33.85	31.00	20.00	25.00
12	33.85	33.00	22.00	27.00

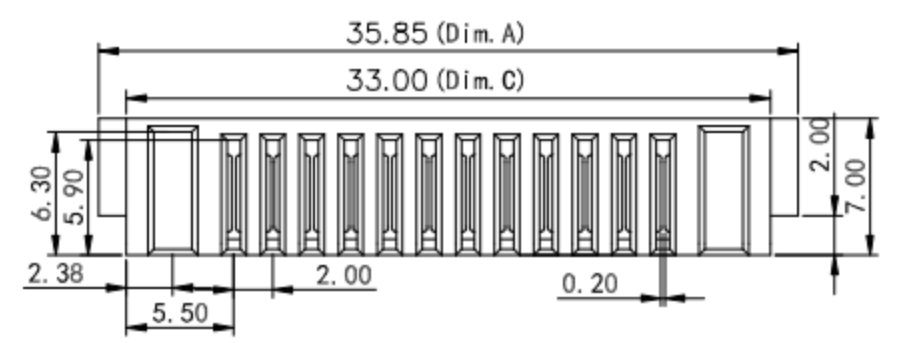
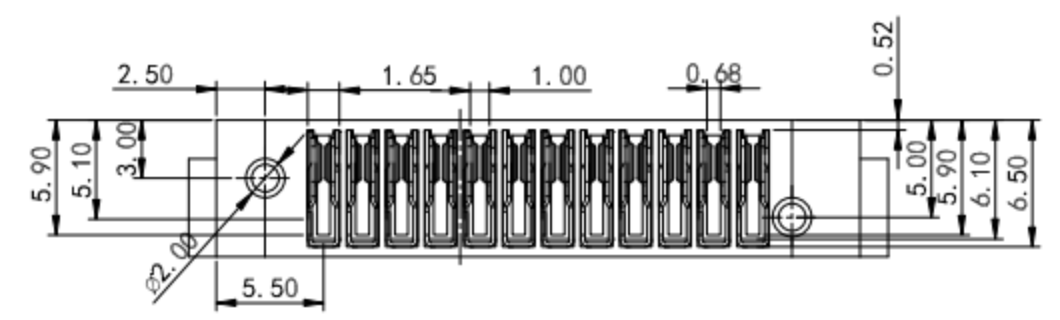
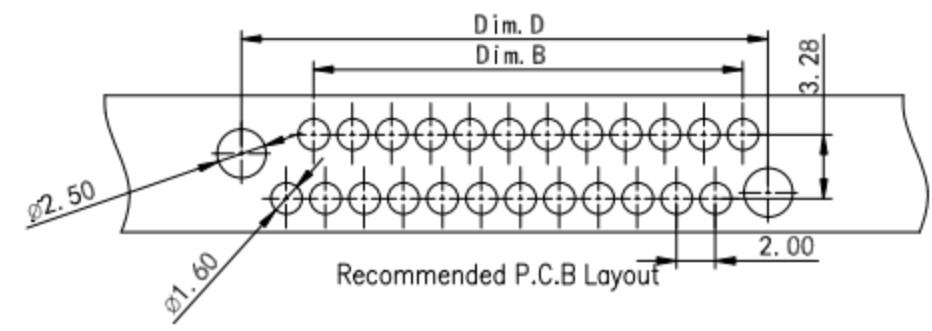
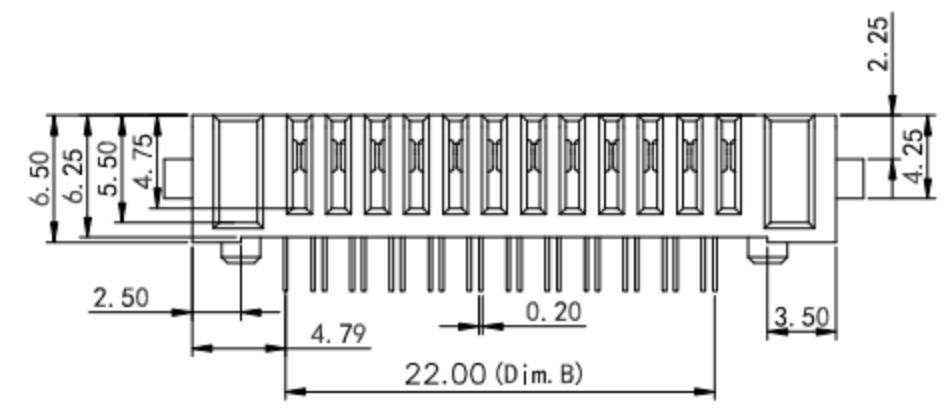

NOTE:  
 Material  
 Insulator:Nylon 9T(UL94V-0)  
 Contact:phosphor Bronze  
 Contact Plated:Gold over Nickel or Tin  
 Specification  
 Rated voltage: 12V 30V  
 Current rating: 3A 5A  
 instant CURRENT:7A  
 Contact Resistance:30MΩ  
 Insulation Resistance:100MΩ  
 Dielectric Voltage:1000V  
 Operdting Temperature:-40°~105°

ITEM	PART NAME	Q'TY	MATERTAL	DESCRIPTION	REMARK
②	HOUSING	1	LCP		BLACK
①	CONTACT A	2	PHOSPHOR BRONZE 0.20T	Au PLATED	

UNLESS OTHERWISE SPECIFIED TOLERANCES			
DECIMALS:		ANGLES:	
DIM	TOL	DIM	TOL
X.	±0.50	X.	±2°
X.X	±0.30	X.X	±1°
X.XX	±0.20	X.XX	
X.XXX	±0.10	X.XXX	

**东莞市高迪电子有限公司**

DWG NO.	PART NAME:
DESIGN:	PART NO.
CHECK:	REV. A
APPROVED	UNIT: mm
	SHEET: 1/1